

硬质合金四孔柄钢板钻 (DNTF)
Carbide annular cutter with FEIN Quick-IN shank(DNTF)

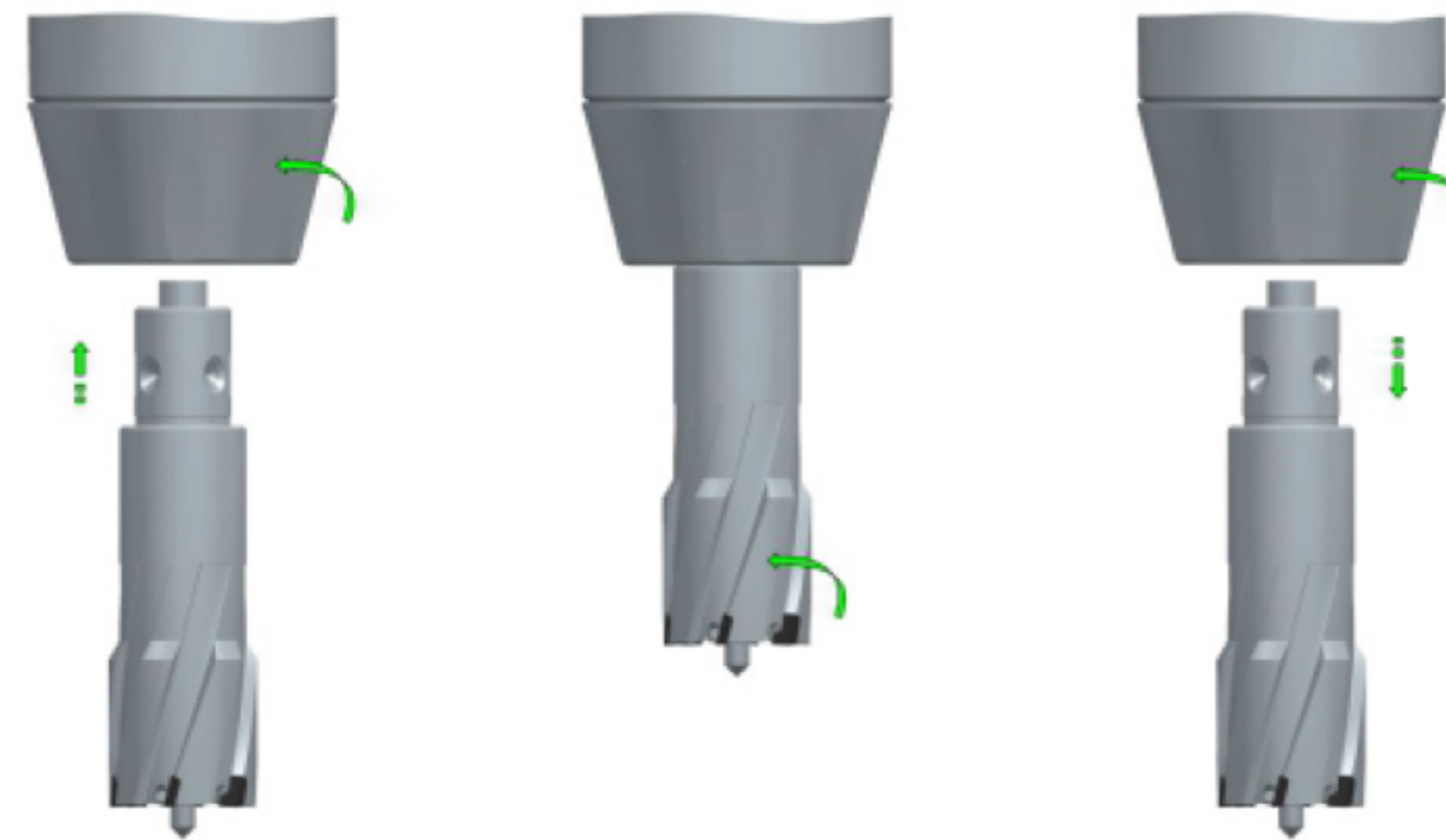

d:直径
d: Diameter
L:钻孔的深度
L: Cutting depth

» 安装示意图:
Installation schematic diagram:



» 适用材料:
Applicable material:

材料 Material						
材料名称 Material name	型钢 Profile steel	钢板 Steel plate	管材 Pipe	不锈钢 Stainless steel	铝 Aluminum	铜/锡 Copper /Tin
强度 Strength	<1400N	—	—	<900N	—	—
适用 Application	★★★★	★★★★	★	★★	★★★★	★★★★
材料 Material						
材料名称 Material name	塑料/有机玻璃 Plastics /Organic glass	铸铁 Cast iron	叠层材料 Laminated material	石墨 Graphite	钢轨 Steel track	木 Wood
强度 Strength	—	—	—	—	—	—
适用 Application	★★★★	★★★★	★	★★★★	—	—

» 型号规格:
Model and specification:

型号 Model	DNTF-3	DNTF-4	DNTF-5	DNTF-6
直径d(mm) Diameter d(mm)	Φ12-65	Φ12-65	Φ14-65	Φ14-65
钻孔的深度L(mm) Cutting depth L(mm)	35	50	75	100

» 匹配顶针:
Matched pilot pin:

切深(mm) Cutting depth(mm)	35	50	75	100
直径(mm) Diameter(mm)	Φ12-65	Φ12-65	Φ14-65	Φ14-65
型号 Model	DPB-62090	DPB-62102	DPB-62130	DPB-62160
规格 Specification	6.34*90	6.34*102	6.34*130	6.34*160

» 可选购产品说明:
Optional purchased products:

