

硬质合金三孔柄钢板钻 (DNTG)
Carbide annular cutter with quick change shank(DNTG)

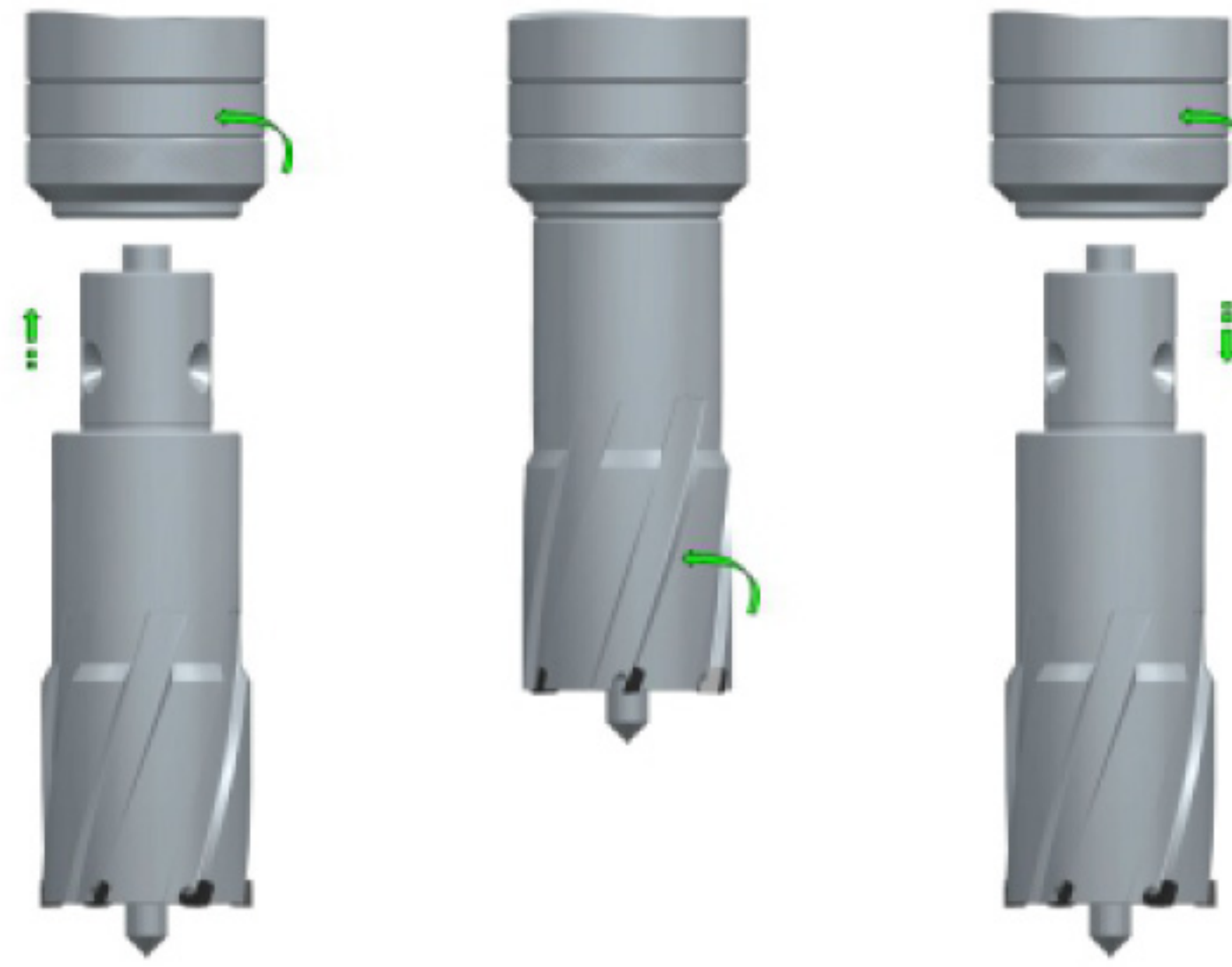

d:直径
d: Diameter
L: 钻孔的深度
L: Cutting depth

» 安装示意图:
Installation schematic diagram:



» 适用材料:
Applicable material:

材料 Material						
材料名称 Material name	型钢 Profile steel	钢板 Steel plate	管材 Pipe	不锈钢 Stainless steel	铝 Aluminum	铜/锡 Copper /Tin
强度 Strength	<1400N	—	—	<900N	—	—
适用 Application	★★★★	★★★★	★	★★	★★★★	★★★★
材料 Material						
材料名称 Material name	塑料/有机玻璃 Plastics /Organic glass	铸铁 Cast iron	叠层材料 Laminated material	石墨 Graphite	钢轨 Steel track	木 Wood
强度 Strength	—	—	—	—	—	—
适用 Application	★★★★	★★★★	—	★★★★	—	—

» 型号规格:
Model and specification:

型号 Model	DNTG-3	DNTG-4	DNTG-5	DNTG-6
直径d(mm) Diameter d(mm)	Φ18-65	Φ18-100	Φ18-100	Φ18-100
钻孔的深度L(mm) Cutting depth L(mm)	35	50	75	100

» 匹配顶针:
Matched pilot pin:

切深(mm) Cutting depth(mm)	35	50	75	100
直径(mm) Diameter(mm)	Φ18-65	Φ18-100	Φ18-100	Φ18-100
型号 Model	DPB-81102	DPB-81115	DPB-81134	DPB-81167
规格 Specification	7.98*102	7.98*115	7.98*134	7.98*167

» 可选购产品说明:
Optional purchased products:

磁座钻机 Magnetic drilling machine	夹具 Arbor	倒角刀 Countersink	钻夹头 Drill Chuck	水壶 (压力) Kettle (pressure)	磁棒 Magnetic bar	转换接头 Adapter